

Application Note

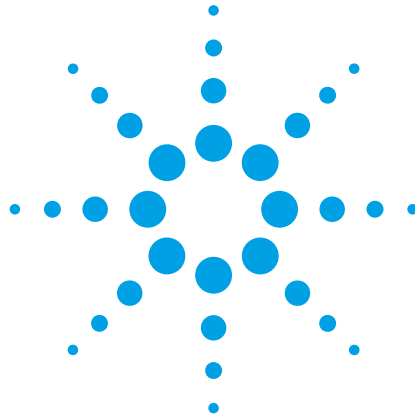

Best of 8 Hints, 1995-2007

for Making Better Oscilloscope Measurements



Agilent Technologies

TABLE OF CONTENTS

HINT 1: Tracking down elusive glitches

In 1999 Page 4

Today Page 5

HINT 2: Analyze harmonic distortion using FFTs

In 1995 Page 6

Today Page 7

HINT 3: Verifying PWM dead time in motor controllers

In 2000 Page 8

Today Page 9

HINT 4: Use holdoff to stabilize complex digital waveforms

In 1995 Page 10

Today Page 11

HINT 5: Troubleshooting infrequent events

In 1995 Page 12

Today Page 13

HINT 6: Using arbitrary waveforms for bit-error testing

In 1999 Page 14

Today Page 15

HINT 7: Correlating software and analog outputs in a CAN controller

In 2000 Page 16

Today Page 17

HINT 8: A quick, easy way to troubleshoot mixed hardware/software prototypes

In 1999 Page 18

Today Page 19

INTRODUCTION

This application note is dedicated to the evolving art of engineering.

From our origins as Hewlett Packard to our modern incarnation as Agilent Technologies, our most popular app notes have been the 8 Hints series. ***The Best of 8 Hints*** is about engineers sharing with engineers. In some cases it's Agilent engineers sharing ideas of how to use the equipment they design. In others, it's our customers submitting their favorite debugging techniques.

We thought it would be fun to take a look at four previous versions of "8 Scope Hints" and see how they have stood the test of time. In some cases, nothing has changed – hardware improvements have just made them more effective. In others, new technologies have changed how these tasks are done.

The 8 Hints series will continue... and they will evolve. Today, they're moving to our web Discussion Forums. Each month in 2007 we will award an MP3/video player to the customer who submits the best hint.

The forums are a great place to interact with other scope users. Agilent engineers also visit the forums regularly. So bring your questions, product suggestions – and most importantly – your debugging hints to **www.agilent.com/find/scopehints**.

1

Tracking down elusive glitches

By Steve Schram,
Invocon, Inc.

Infrequent, unpredictable events

can present some of the toughest trouble-shooting challenges around. I recently encountered such a glitch while designing a low-power data acquisition device. This wireless instrument system uses a group of remote sensor units and spread spectrum radio transceivers (Figure 1). Data collected at the system can be retrieved by a network control unit connected to a computer. The system uses the interrupt pin on a low-power clock chip to trigger power-up events every 60 seconds.

Between events, the clock and supporting logic are the only devices drawing current (approximately 50 μ A). After getting a trigger from the clock, the Motorola 68HC11K1 microcontroller powers up, collects temperature data and listens for transceiver activity. If it hears a data request on the transceiver, the MCU

transmits the temperature data. The glitch in question was showing up during this 60-second interval, when the system was supposed to be quiet. To find and analyze this anomaly, I used a deep memory (1 Mbyte) digital oscilloscope with peak detect. Since the glitch occurred so infrequently, I first set the scope's time base at 10 seconds/division in order to capture the entire 60-second sequence. Without peak detect, most narrow events would be impossible to detect at this time base setting. But as Figure 2 shows, the glitch in my system was easily captured and viewed.

Peak detect showed something unusual happening approximately 15 seconds after the clock trigger event.

Once I became aware of the anomaly's presence in my system, the scope's deep memory made it easy to zoom in and analyze the glitch in more detail. With the scope's 1 Mbyte of acquisition memory, the initial waveform capture at 10 seconds/division was also sufficient to see waveform details when I zoomed in and viewed at 10 milliseconds/division (Figure 3).

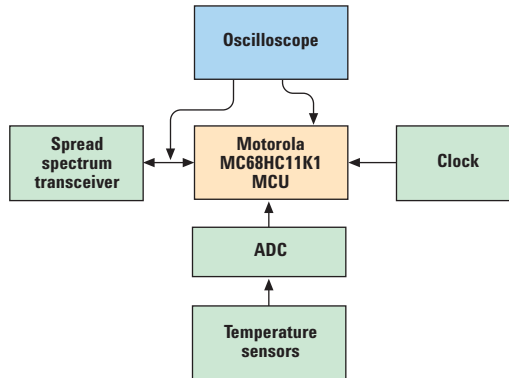

Figure 1

Basic block diagram of the wireless instrumentation system. One analog input on the scope monitored power-up on the MCU while the other monitored the carrier detect signal feeding the transceiver.

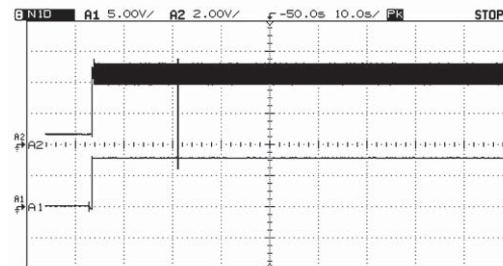

Figure 2

The initial measurement using peak detect with a 10 s/div time base setting.

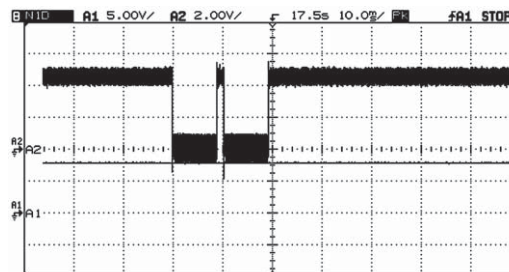

Figure 3

Once the glitch was identified, zooming in to a faster time base setting provided the necessary details.

T O D A Y



...with 5000 Series scopes

Technique also applies to
6000 Series and
8000 Series scopes

MegaZoom III is the third generation of the fast and deep memory architecture that Agilent first introduced in 1996. It combines fast, responsive deep memory with a high-resolution display system that makes it easier than ever to find elusive signal anomalies.

Deep memory allows you to see long periods of time at a high sample rate. This

allows you to view complex modulated waveforms without aliasing, analyze lengthy system boot-up sequences, zoom deeply into slow/fast signals, and have excellent resolution in the frequency domain.

You can learn more about the benefits of deep memory in Application Note 1446: *Deep-Memory Fast Response Oscilloscopes: The New Tools of Choice.*

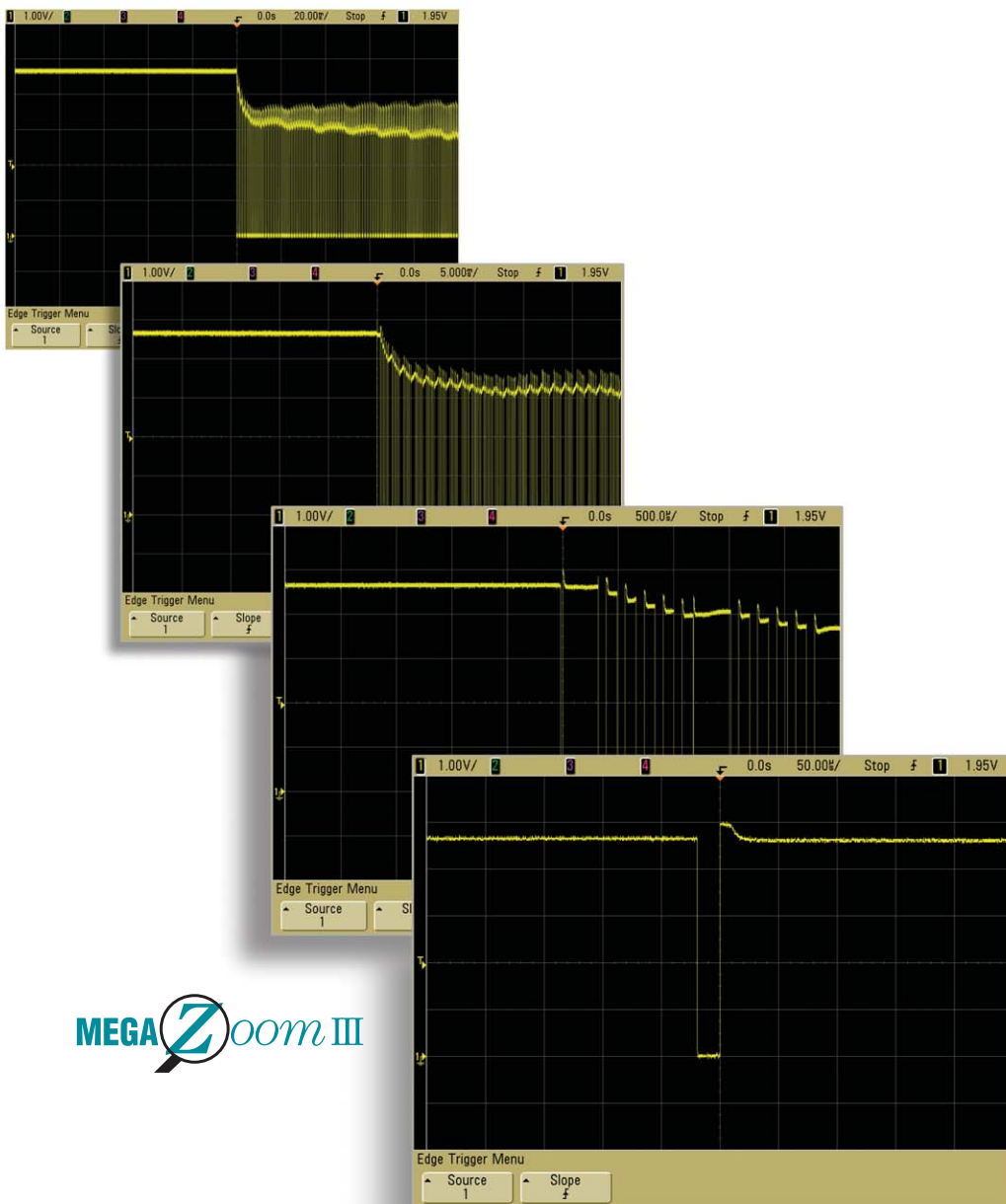

MEGA **Z**oom III

HINT

2

I N 1 9 9 5 . . .

Analyze harmonic distortion using FFT

With amplifiers so widely used in electronic devices, harmonic distortion is a common problem faced by design engineers. To characterize a prototype amplifier, you can input a spectrally pure sine wave and look at the amplifier output on your scope. In this example (Figure 1), the sine wave looks distorted.

To get a different point of view, try doing the FFT of the sine wave (Figure 2). Observe the harmonics.

The FFT gives you more quantitative information on how much harmonic distortion there is in the amplifier design. The fundamental frequency is at 50 kHz. The second harmonic at 100 kHz is only 17.81 dB down from the fundamental, indicating serious harmonic distortion. Built-in FFT capability in a scope lets you take a quick look at the frequency domain, in addition to the time domain.

Figure 1

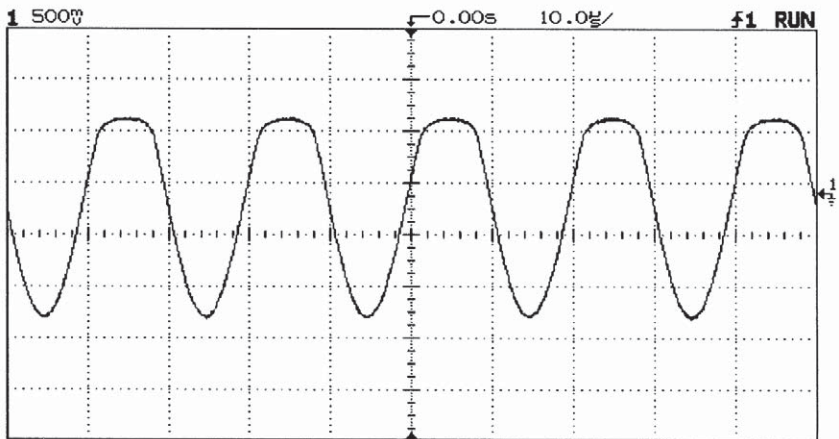
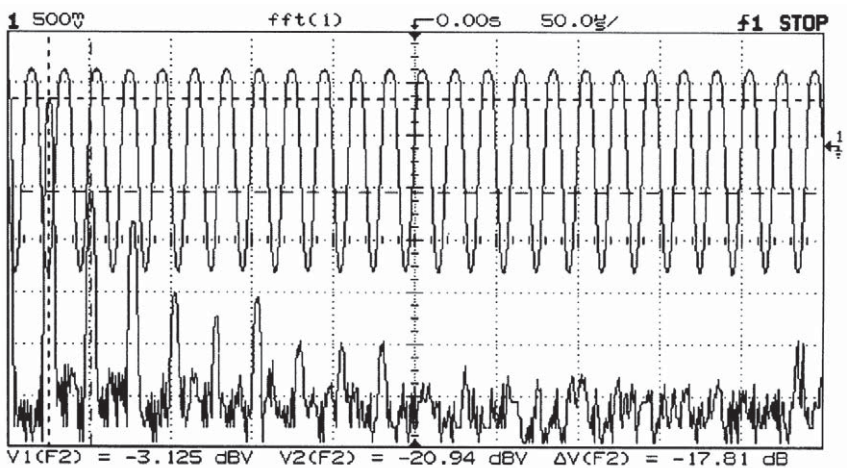

Figure 2



T O D A Y



...with 6000 Series scopes

Technique also applies to
8000 Series and
80000 Series scopes

Agilent oscilloscopes still offer an FFT function; but today, frequency domain analysis has been dramatically enhanced with the introduction of 89601A vector signal analysis software for oscilloscopes.

This software allows you to conduct wide-band signal analysis with 6000 Series oscilloscopes and other high-performance Agilent scopes. Agilent's deep memory capture provides superior demodulation dynamic range and frequency resolution.

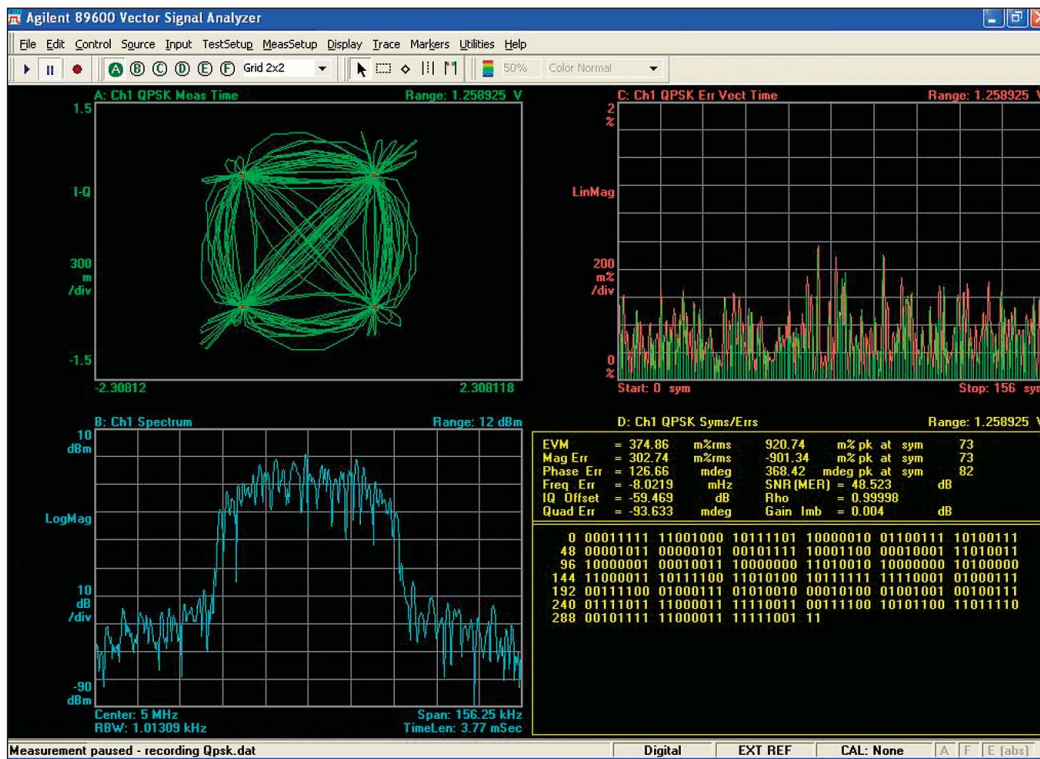

3

Verifying PWM dead time in motor controllers

By Technical staff,
Infineon Technologies

Generating pulse width modulated (PWM) signals with an MCU is a common way to control AC motors with sine-wave shaped currents. A typical application for an 8-bit MCU is controlling a three-phase induction drive with variable speed in an open-loop configuration.

However, the MCU can't drive an induction motor directly, so you need to amplify the three-phase signals first. Instead of using analog amplifiers, a more efficient way is to digitally amplify the PWM outputs with power switches, such as MOSFETs or IGBTs. The three-phase inverter shown in Figure 1 accomplishes this function. The hardware for each phase of the inverter consists of two power switches (high side and low side) in

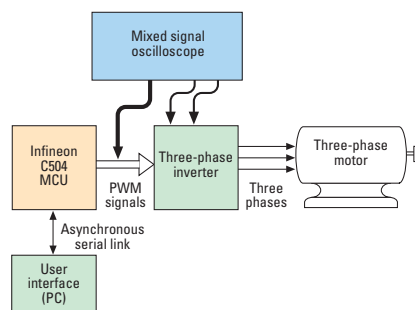

Figure 1

a push-pull configuration. This creates a potential problem, though, if the control signals for the switches are exact complements of each other. During PWM switching, both power switches might momentarily conduct simultaneously due to different transistor turn-on and turn-off latencies. This can create a high-current short circuit and may destroy the inverter. It's therefore important to use an MCU optimized for motor control, such as the Infineon C504 (an 8051 derivative) or C164 (16-bit architecture). Both can be programmed to insert "dead time" in the PWM outputs by hardware without any software overhead. The dead time ensures that the two switches never conduct at the same time. After programming the microcontroller to create the PWM output signals with dead time, the next step is testing the wave shape and timing. A four-channel scope can do the basic measurement, but

if one is available, a mixed-signal scope is a better choice because you can measure multiple analog and digital waveforms simultaneously and set up complex logic triggers.

Figure 2 verifies that the programmed dead time is sufficient for safe PWM switching. This zoomed-in display shows the impact of the dead time on the analog gate-source voltage of the power switch MOSFETs. The scope's cursors simplify the correct timing measurement and help characterize the circuit precisely. With combined digital and analog measurement channels, you can easily monitor all six PWM signals and the phase currents. Figure 3 shows the two phase currents and corresponding digital PWM pattern. The time-qualified trigger mode lets you synchronize the scope's display to an adjustable pulse width corresponding to a well-defined phase angle.

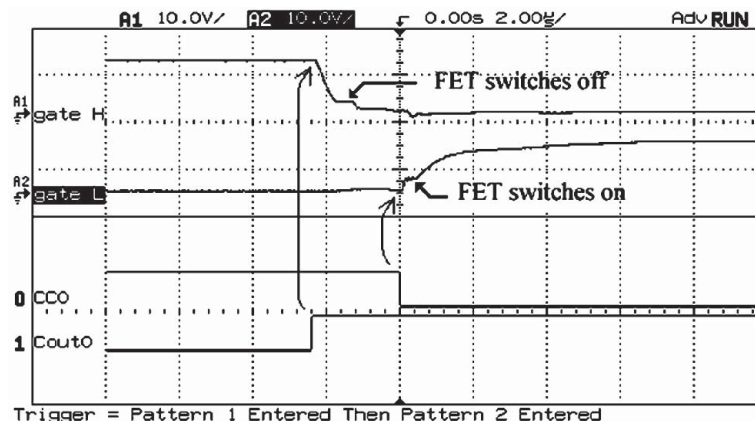

Figure 2

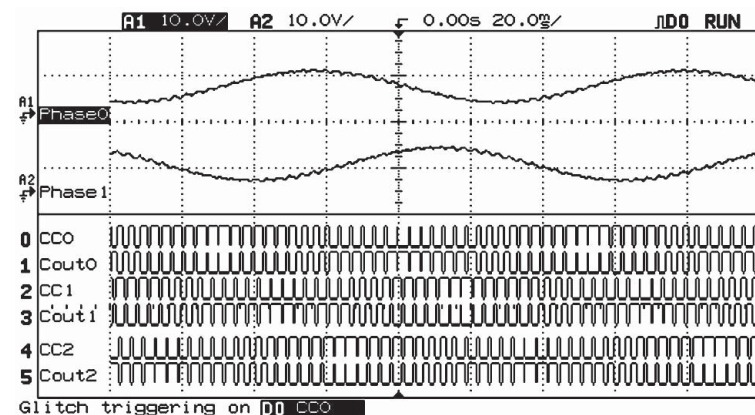

Figure 3

T O D A Y

It's been 10 years since the 54645D mixed-signal oscilloscope (MSO) won Test Product of the Year awards, and the reach of MSO technology continues to grow. MSO capability is available in the 6000 Series portable scopes; and customers who need more analysis power can now purchase MSO versions of the Infiniium 8000 Series lab scopes.

(MSOs) tightly correlate 2 or 4 analog channels with 16 logic timing channels. MSOs combine all of the measurement capabilities of a digital storage oscilloscope (DSO) with some of the measurement capabilities of a logic analyzer, along with serial protocol analysis – in a single instrument. You are able to see multiple time-aligned analog, parallel, digital, and serially decoded waveforms on the same display.



...with 6000 Series scopes

Technique also applies to
8000 Series scopes

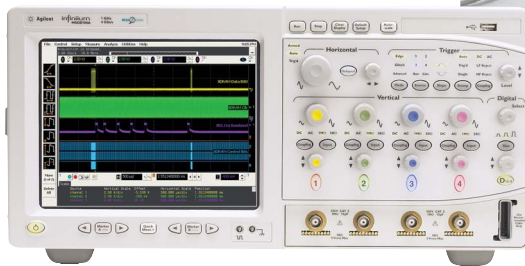
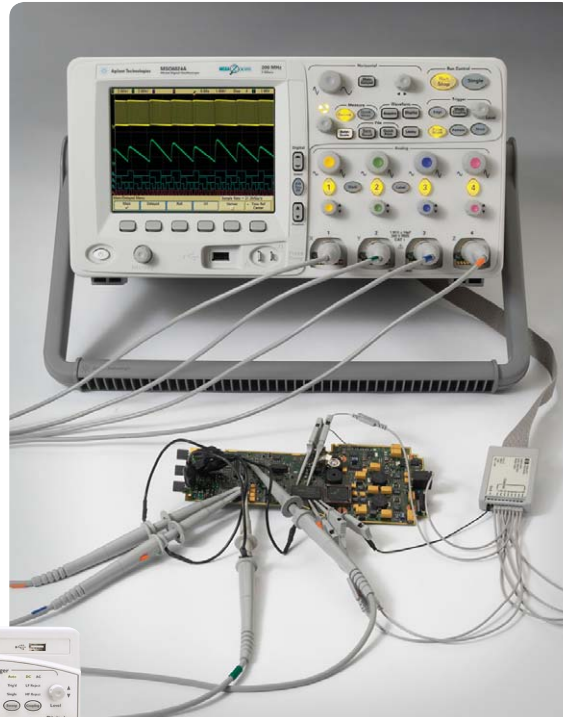

HINT

4

Use holdoff to stabilize complex digital waveforms

I N 1 9 9 5 . . .

Scope users typically start out using edge triggering. In this mode, the scope will trigger on any edge that meets the setup criteria, for instance any rising edge on channel 1 at 1.5 V. The trigger event becomes the time reference for displaying the data. This presents a problem when there are many edges at different positions in the waveform that meet this criteria, as is the case with complex waveforms. The scope triggers on multiple edges and overlays the waveforms with different time references. The result is a complicated display that looks untriggered (See Figure 1).

Try using your scope's holdoff feature to stabilize such a waveform. When holdoff is used, the scope triggers on the first rising edge it sees, but then waits the holdoff time before re-arming the trigger event. Use a holdoff time just less than the period of the repetition of the waveform. For this example, the holdoff time is 28 ps. (See Figure 2). The scope now triggers on the same edge every time, so the data has the same time reference each time it is displayed. It is now evident that there is an intermittent glitch.

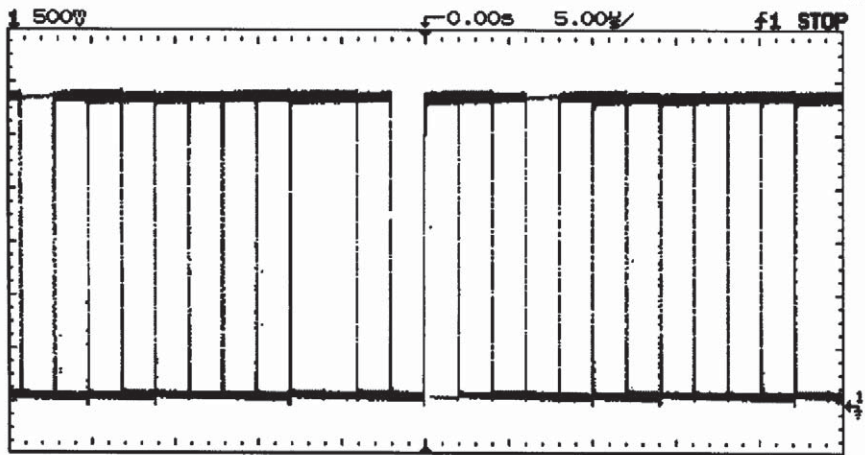

Figure 1

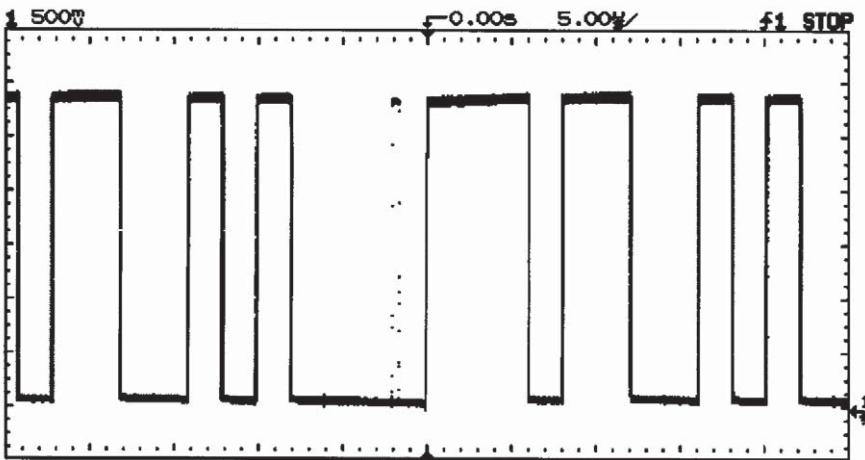

Figure 2

T O D A Y



...with 6000 Series scopes

Technique also applies to 8000 Series scopes

Trigger holdoff is still an excellent technique for stabilizing complex pulse trains. However, in the case of serial buses, you will get even better results with dedicated hardware serial triggers.

The 6000 Series oscilloscopes offer hardware triggering for popular buses like I²C, SPI, CAN, LIN, and USB. Triggering on addresses, data patterns, frames, packet

states, or other signal conditions makes it easier to isolate specific conditions on your buses.

Optional hardware-assisted serial decoding toolsets for the 6000 and 8000 Series scopes give you even more insight with time-aligned analog, digital, and serial bus information.

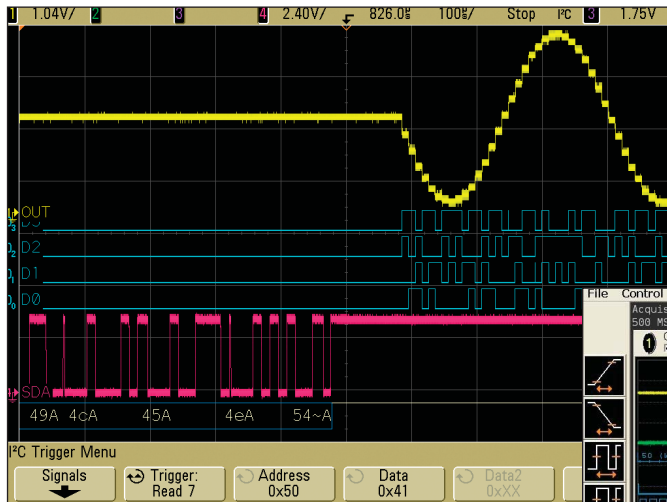

6000 Series CAN trigger

8000 Series USB decode

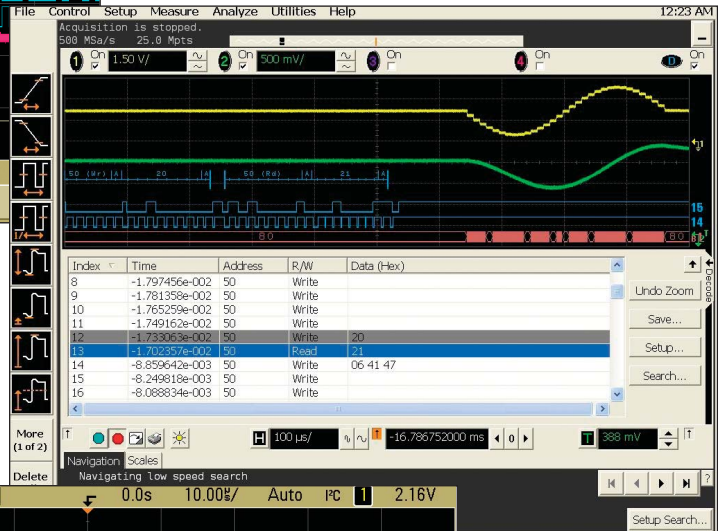

6000 Series I²C decode

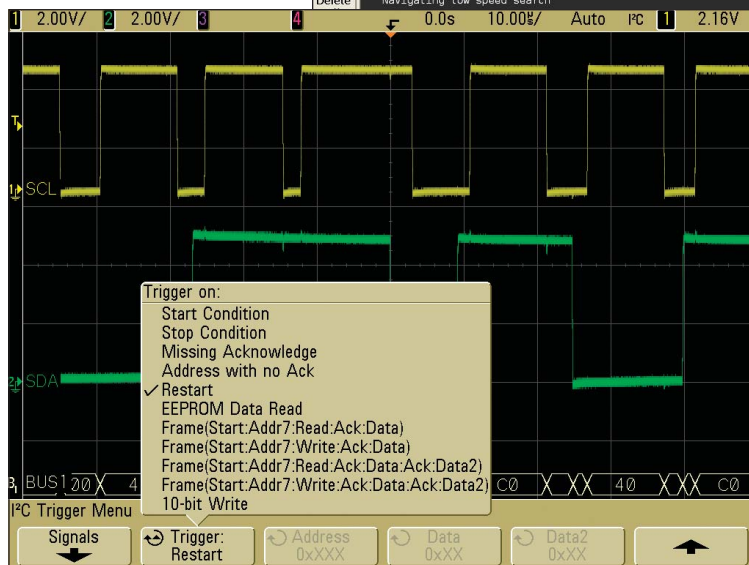

HINT

5

I N 1 9 9 5 . . .

Troubleshooting infrequent events

When troubleshooting or characterizing a circuit, take advantage of the triggering capabilities of your scope. Some scopes are able to time qualify the trigger. You can tell the scope to trigger only if it sees an event wider than, or narrower than, a specified width. This is very useful when looking for infrequent events.

For example, if you know that a strobe pulse must be at least 30 ns wide, you can set up your scope to trigger on a pulse that is < 30 ns. The trigger circuit will look at every pulse, if pulses are at least as far apart as the reset time for the trigger

circuit. If the scope triggers, there's a problem. If it doesn't trigger there isn't a problem. Scopes can process tens of millions of events per second in this way.

In Figure 1 the scope is edge triggered on a rising edge of channel 1 and the strobe pulse appears to be good (≤ 30 ns wide).

In Figure 2, the scope is set up to trigger on a negative-going pulse that is present for less than 30 ns. The scope triggered, verifying that sometimes the strobe pulse is bad (< 30 ns wide).

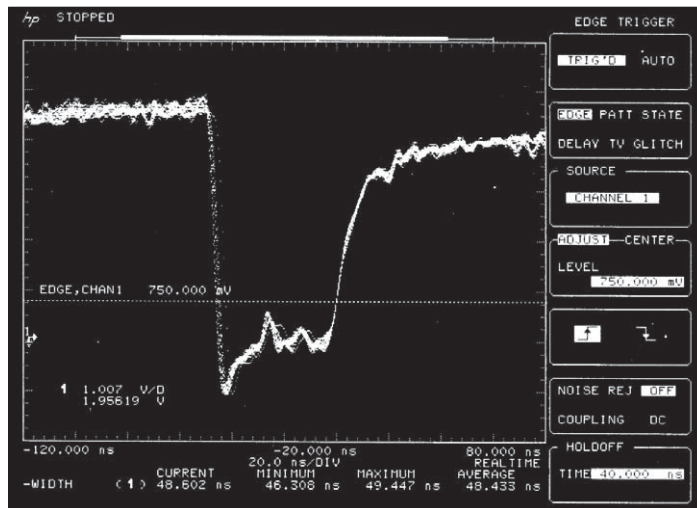

Figure 1

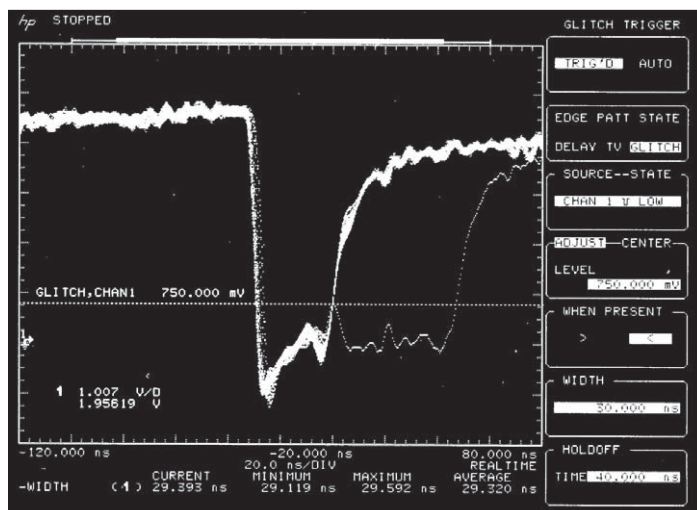

Figure 2

T O D A Y

Pulse-width triggering is still an excellent technique for identifying suspected glitches. When browsing for unknown glitches, however, the update rate of the oscilloscope becomes a key specification.

The next-generation MegaZoom III technology in Agilent's 5000 and 6000 Series oscilloscopes update at a rate of up to 100,000 waveforms per second in their real-time acquisition mode.

With a fast update rate, the "dead time" between acquisitions is much smaller. A

scope with a slower update rate will capture the glitch if you wait long enough (and if it recurs), but most engineers and technicians don't have the time or patience to wait for their scopes to catch up with their browsing. A fast update rate allows you to move quickly from signal to signal and rule out glitches with confidence.

Learn more about the benefits of a fast update rate from Application Note 1551: *Improve Your Ability to Capture Elusive Events: Why Oscilloscope Waveform Update Rates are Important.*



...with 5000 Series scopes

Technique also applies to
6000 Series and
8000 Series scopes

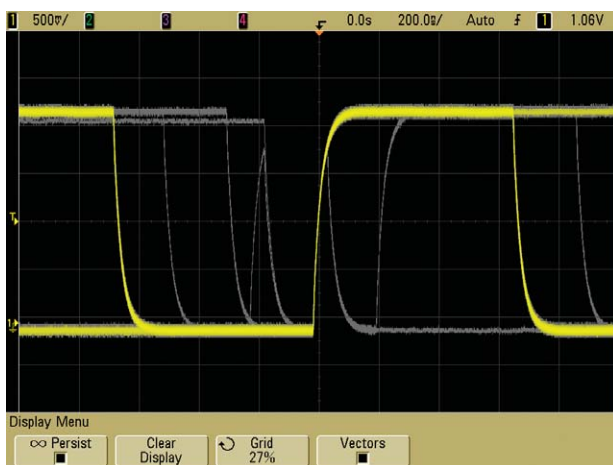
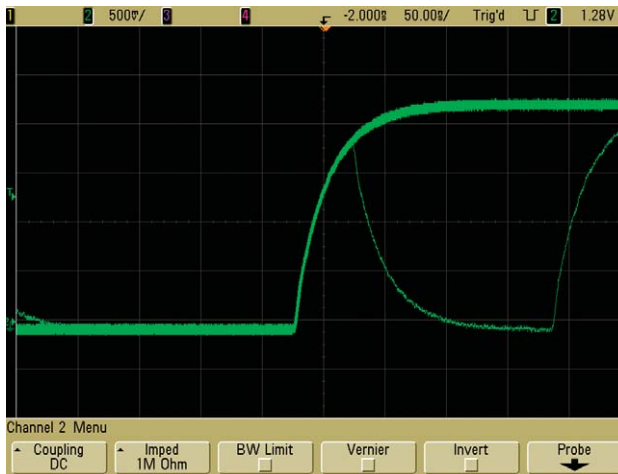

MegaZoom III improves your chances of finding isolated events by up to 100 times.

See more events

Your chances of finding a glitch increases as the update rate increases. If a glitch occurs during the "dead time" between samples, you miss it. With MegaZoom III acquisition technology, the dead time is much smaller. This improves your chances of finding isolated events by up to 100 times, and speeds up automated test dramatically.

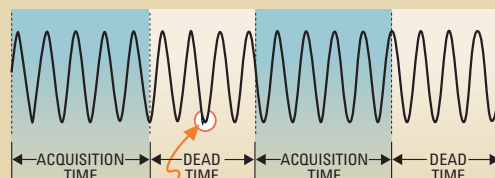

GLITCH
Reducing the DEAD TIME
between acquisitions...
...improves your chances of finding
random, events like GLITCHES

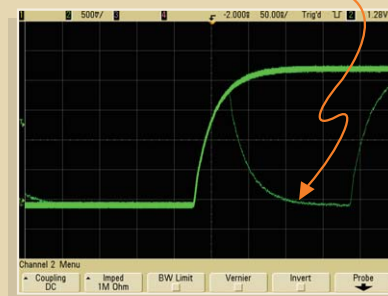

6

Using arbitrary waveforms for bit-error testing

By Jim Clark, LPA Design

As digital communications designers, we often need to test data reception software to make sure that bit errors are properly detected. Whether it's a wired or wireless system, when we test over short distances on the lab bench, reception is usually too good to encounter random bit errors. When an error does occur, it is usually not very repeatable. This is where an arbitrary waveform generator comes in handy. Digitizing a very clean and verified waveform that represents a digital data packet and storing it on a computer for replay with an arb generator opens up a whole new means of bit error testing. By capturing the clean waveform on a deep memory digital scope and transferring it to a PC using instrument software such as HP BenchLink or LabVIEW®, we can then change the waveform and introduce noise

or other interference to fully verify proper reception on the device under test (DUT). We play the modified signal back to the DUT by downloading the new waveform into the arb generator and substituting this waveform for the original signal source.

Figure 1 shows the block diagram of an OOK (on/off keyed) data receiver we're designing. Figure 2 shows a clean (error-free) packet of data that I captured from the received signal strength indicator (RSSI) output using a deep-memory scope. I then uploaded this waveform to my PC using HP BenchLink software. Then it was a simple matter of cutting the waveform from the HP BenchLink software screen and pasting it directly into the arb editor. I saved this waveform as my "perfect"

original. I then used the math and edit tools in BenchLink to add random noise and reduce the amplitude to simulate path loss. The resulting signal was downloaded into the arb generator to generate a substitute RSSI signal (Figure 3). The receiver is fed this new noisy signal to see if its software still recognizes the data. It's easy to go back and add more and more noise until bit errors occur. Then it's a simple matter to verify that errors are detected and/or corrected, depending on the receiver.

The arb generator also makes it possible to edit a specific bit or set of bits to make sure that errors in all positions are detected. Another key advantage is saving the modified waveforms to ensure a consistent signal from test to test.

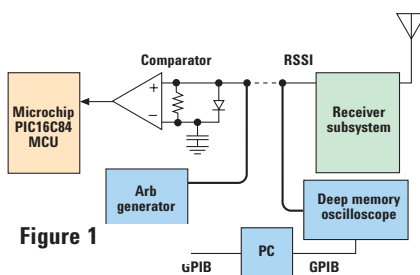

Figure 1

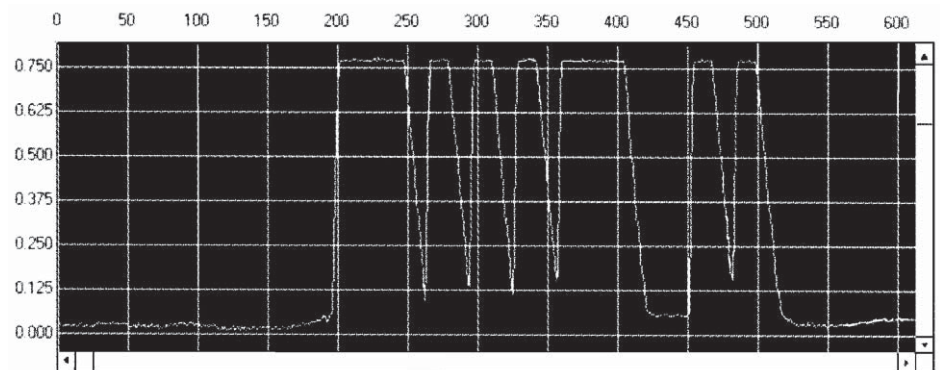

Figure 2

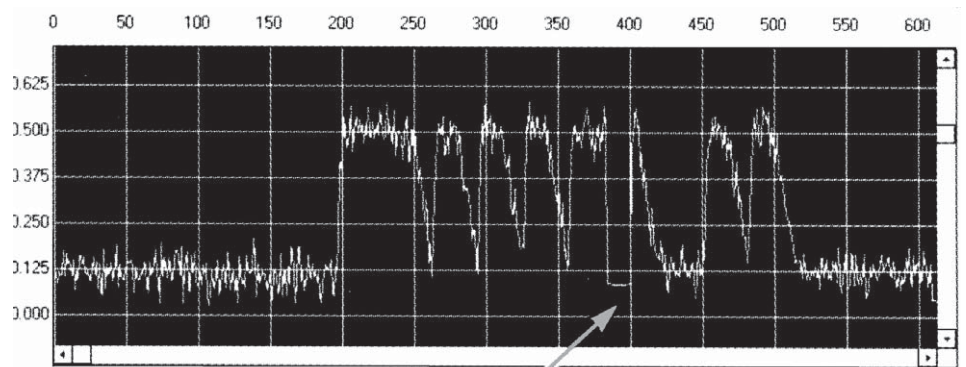

Figure 3

Bit error added here

LabVIEW® is a U.S. registered trademark of National Instruments Corporation.

T O D A Y

Instrument interconnectivity and interoperability are more important today than ever, and Agilent's instruments are evolving to meet this need.

The Agilent 5000, 6000 and 8000 Series oscilloscopes are LXI (LAN eXtensions for Instrumentation) class C compliant. These oscilloscopes follow specified LAN protocols, and adhere to LXI requirements such as a built-in Web control server, IVI-COM drivers, and easy-to-use SCPI commands. The standard Agilent IO Library Suite makes it easy to configure and integrate instruments within your test systems.

You can access this functionality through standard USB (3), LAN, and GPIB ports. You can even import scope data and screen shots directly into Microsoft® Word and Excel through handy IntuiLink toolbars.

You can learn more about the Agilent Open LXI program from www.agilent.com/find/LXI.



...with 8000 Series scopes

Technique also applies to

5000 Series,

6000 Series and

80000 Series scopes

LXI

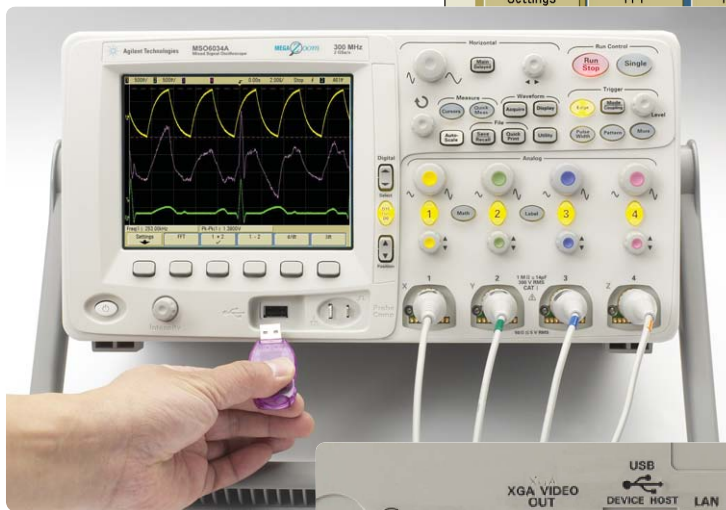
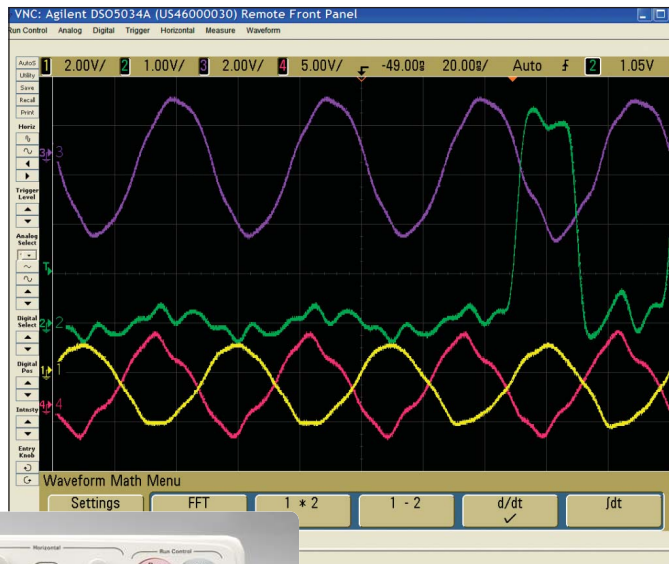

Flexible hardware and software connectivity tools in today's oscilloscope give you more options than ever for integrating your bench.



Microsoft® is a U.S. registered trademark of Microsoft Corporation.

HINT

I N 2 0 0 0 . . .

Correlating software and analog outputs in a CAN controller

By Pascal Mestdagh,
EUROCORPS, Telecommunications Division

Until recently, troubleshooting mixed signal designs, where you need exact time coherency between analog signals and MCU code, was extremely difficult. The problem could be partially solved by combining a logic analyzer and an oscilloscope with common time bases and triggering them simultaneously. However, time base differences between the two instruments could lead to incorrect results. Moreover, differences in memory made things even more difficult. An alternative is to use a hybrid scope/logic analyzer. These instruments enhance cross-domain measurement accuracy and can reduce debugging time for mixed-signal designs. In my application, where a Philips 80C51 MCU interacts with an 82C200 CAN (Controller Area Network) control chip to establish low-speed data communication between several domotics (home automation) devices, it is not always easy to determine the cause of an emerging problem. In this specific case, problems arose when I tried to send data to a remote device. It seemed as though several bytes were not arriving at their destination. I connected the digital inputs of the scope to the MCU data bus and connected the scope's analog inputs

to the transmission line (Figure 1). I then used pattern triggering to synchronize the measurement to the specific transmission request code word for the 82C200. Next, I set the trigger pattern in such a way that the measurement system triggered when the code word and the desired transmission frame occurred simultaneously. I quickly discovered that I had a software problem and had to review the code. Contrary to my first assumption, the test revealed that a data loss existed between the MCU and the CAN controller, and not on the transmission line (Figure 2).

The integrated scope and logic channels made it possible to compare with great accuracy the analog signals with their digital originators (the MCU code). In addition, deep memory is a big plus, since it let me sample the full length of the transmission frame (approximately 300 ms) and at the same time have enough detail to investigate the microcontroller code (approximately 150 ns). Although conventional test equipment probably could've solved this problem, I saved a considerable amount of time using a hybrid analog/digital solution with deep memory.

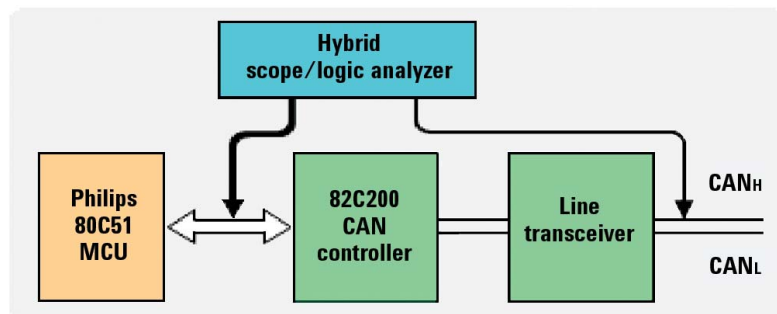

Figure 1: Measurement connections used to debug the CAN controller setup

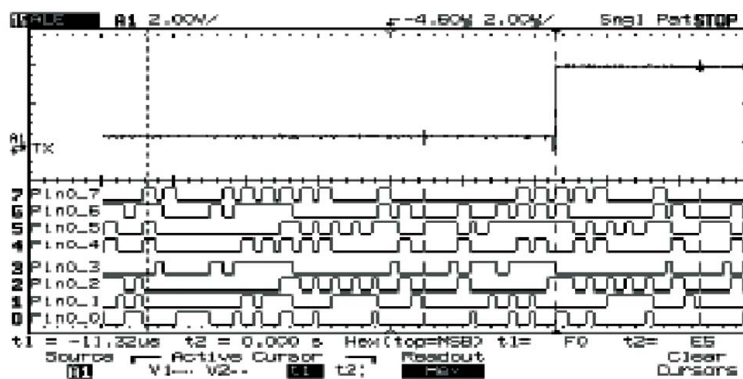

Figure 2: The simultaneous occurrence of the transmission request code word and the analog transmission frame revealed an inconsistency in my software code. Bytes did not arrive at their destination because the MCU didn't verify the "transmission complete" bit of the status register in the CAN controller.

T O D A Y



...with 6000 Series scopes

Automotive buses have become increasingly standardized in the last 5 years, and they are now used in all sorts of embedded designs. Agilent's support for these technologies has grown to make debugging these designs much simpler.

Agilent 6000 Series mixed signal oscilloscopes combine up to 18 channels of signal and bus analysis with standard triggering support for CAN and LIN. These scopes also offer optional hardware-enhanced decode to maintain their lightning-fast update rates when analyzing these buses.

The DSO/MSO6000A oscilloscopes also offer support for FlexRay buses, a battery option for field operation, and a unique 1U rack-sized option (6000L Series DSOs and MSOs) to allow your R&D test setup to be migrated to manufacturing.

You can learn more about debugging CAN bus in Application Note 1576: *Using an Agilent 6000 Series MSO to Debug an Automotive CAN Bus*.

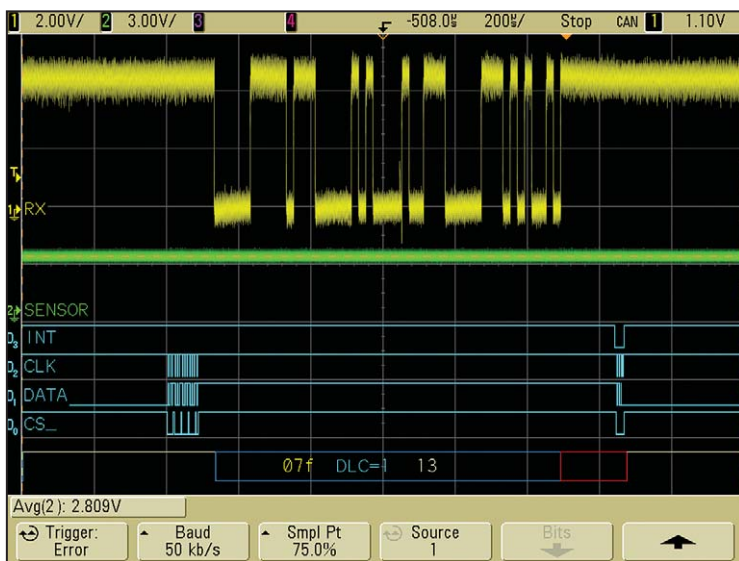
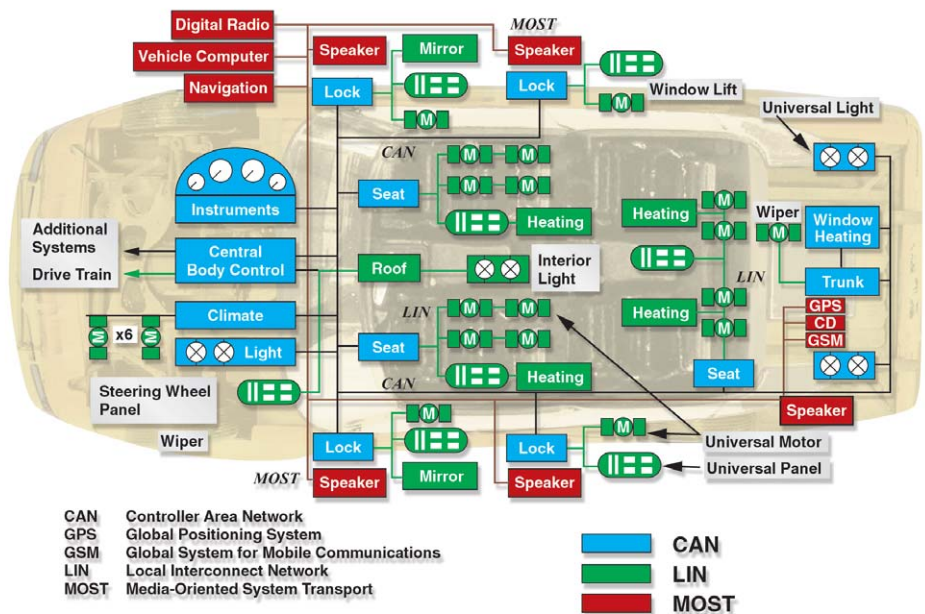

HINT

I N 1 9 9 9 . . .

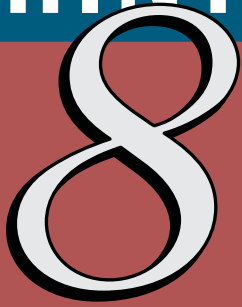

A quick, easy way to troubleshoot mixed hardware/software prototypes

By Steve Hendrix

The process of designing and troubleshooting hardware driven with software often involves looking at lengthy and complex bit streams. It's often quite an effort to trigger the scope at the exact place in the bit stream you need to look at. An easy way around this is simply to find an unused I/O pin on the prototype as a trigger point, and insert code into the software to toggle that pin at the appropriate time. You can even use this capability to look at other signals occurring before the event of note. Sure, digitizing scopes often have fairly advanced triggering capabilities, and many can be set up to capture complex events like this. However, if the engineer can easily program a sync pin, you've saved the trouble of learning more complex scope features, and you're in complete control via SW of where the trigger will occur. Steve notes that such a sync capability can even be left intact in production code *if* it is well documented; that can make a field service and diagnostic work much easier, too.

Steve is an independent consultant offering hardware and software design and other electrical engineering services. His clients are primarily small high-tech companies that are pushing the edge of new technologies. He enjoys the verity afforded by working for different companies and the learning opportunities that come his way as a result.

Steve is frustrated by companies that sell "vaporware." And he hates wasting his valuable time playing telephone tag to get critical product information. "With time-to-market pressures, the price and delivery lead times are every bit as important as voltage or current specs," he says.

T O D A Y

FPGAs have become pervasive in hardware development, and they have replaced the standalone microprocessor in many designs. In-circuit debug of FPGA designs helps to uncover, in a few seconds, problems that may have required days, weeks or months to simulate. Development teams can benefit greatly from effective debug tools for FPGAs and the surrounding systems.

Agilent pioneered “core-assisted” instrument debug of FPGAs and is currently shipping the third generation on-chip technology. The application delivers two key values:

Incremental real-time internal measurements without:

- Stopping the FPGA
- Changing the design
- Modifying design timing

Quick MSO setup:

- FPGA pins to MSO digital channels
- Signal and bus names



...with 8000 Series scopes

Technique also applies to 6000 Series scopes

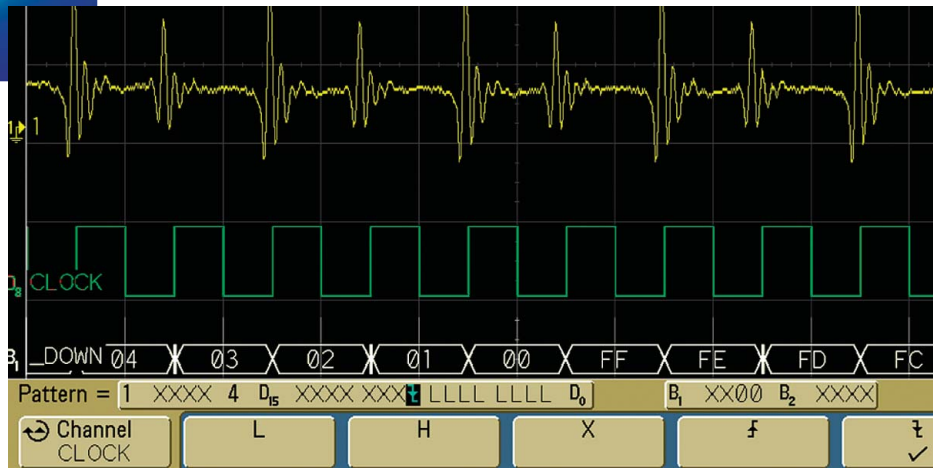
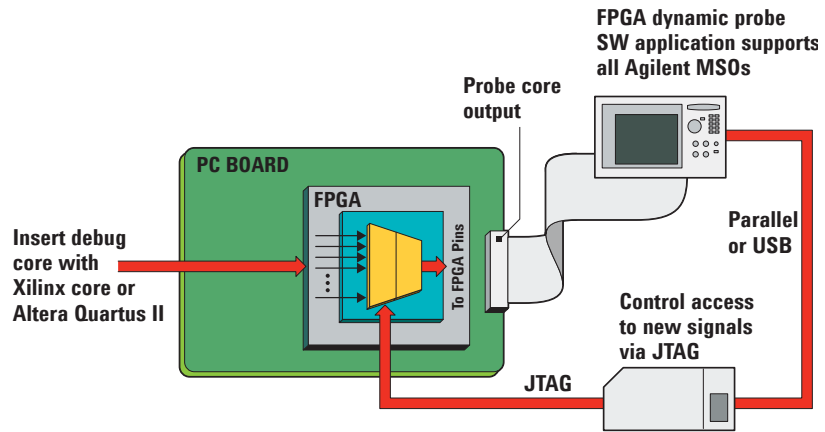



Agilent Email Updates

www.agilent.com/find/emailupdates

Get the latest information on the products and applications you select.



Agilent Direct

www.agilent.com/find/agilentdirect

Quickly choose and use your test equipment solutions with confidence.



www.agilent.com/find/open

Agilent Open simplifies the process of connecting and programming test systems to help engineers design, validate and manufacture electronic products. Agilent offers open connectivity for a broad range of system-ready instruments, open industry software, PC-standard I/O and global support, which are combined to more easily integrate test system development.



www.lxistandard.org

LXI is the LAN-based successor to GPIB, providing faster, more efficient connectivity. Agilent is a founding member of the LXI consortium.

Remove all doubt

Our repair and calibration services will get your equipment back to you, performing like new, when promised. You will get full value out of your Agilent equipment throughout its lifetime. Your equipment will be serviced by Agilent-trained technicians using the latest factory calibration procedures, automated repair diagnostics and genuine parts. You will always have the utmost confidence in your measurements.

Agilent offers a wide range of additional expert test and measurement services for your equipment, including initial start-up assistance onsite education and training, as well as design, system integration, and project management.

For more information on repair and calibration services, go to

www.agilent.com/find/removealldoubt

www.agilent.com

For more information on Agilent Technologies' products, applications or services, please contact your local Agilent office. The complete list is available at:

www.agilent.com/find/contactus

Phone

Americas

Canada	(877) 894-4414
Latin America	305 269 7500
United States	(800) 829-4444

Asia Pacific

Australia	1 800 629 485
China	800 810 0189
Hong Kong	800 938 693
India	1 800 112 929
Japan	81 426 56 7832
Korea	080 769 0800
Malaysia	1 800 888 848
Singapore	1 800 375 8100
Taiwan	0800 047 866
Thailand	1 800 226 008

Europe

Austria	0820 87 44 11
Belgium	32 (0) 2 404 93 40
Denmark	45 70 13 15 15
Finland	358 (0) 10 855 2100
France	0825 010 700
Germany	01805 24 6333* *0.14€/minute
Ireland	1890 924 204
Italy	39 02 92 60 8484
Netherlands	31 (0) 20 547 2111
Spain	34 (91) 631 3300
Sweden	0200-88 22 55
Switzerland	(French) 44 (21) 8113811 (Opt 2)
Switzerland	(German) 0800 80 53 53 (Opt 1)
United Kingdom	44 (0) 7004 666666

Other European countries:
www.agilent.com/find/contactus

Revised: March 23, 2007

Product specifications and descriptions in this document subject to change without notice.

© Agilent Technologies, Inc. 2007
Printed in USA, August 7, 2007
5989-6387EN



Agilent Technologies